

CC1220A54L TO-247-4L

SiC Power MOSFETs

CoolCAD Power MOSFETs exceed power, efficiency and portability capabilities of standard silicon devices and are available in a variety of breakdown voltages (650V, 1200V, 1700V & 3300V) and current ratings. They have low on-resistance and low leakage in the blocking state. Fabricated on high-quality SiC epitaxial layers, our proprietary fabrication process includes carefully chosen annealing procedures to ensure a high-quality SiC-SiO₂ gate oxide dielectric layer. Doping profile, neck region, and edge termination ensure extremely low R_{on} and high breakdown voltage.

BENEFITS

- ✓ Higher efficiency
- ✓ Reduced cooling
- ✓ Increased power
- ✓ Reduced system volume

APPLICATIONS INCLUDE

Electromechanical power converters, DC to DC, AC to DC and DC to AC converters, switching power supplies, electric vehicles, hybrid vehicles, solar and wind energy power converters.

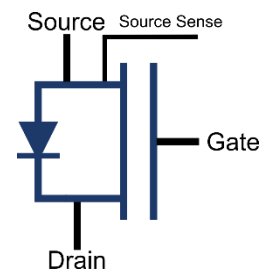
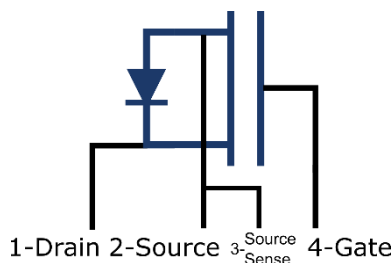

Part Number	Package	Marking
CC1220A54L	TO-247-4L	CoolCADElectronics

* For description only. No rights are granted. No liability is assumed for choice of products.

Maximum Ratings						
*Characteristics	Symbol	Comments	Min	Typ	Max	Units
DC blocking voltage	V_{DSmax}	$T_J=25^{\circ}C$ to $175^{\circ}C$	1200			V
Gate input voltage range	V_{GS}	Recommended range Dynamic	-5 -7		20 23	V
Avalanche rating	V_{AVA}	$V_{GS}=0V$; $I_{DS}=1mA$; $T_J=25^{\circ}C$ $V_{GS}=0V$; $I_{DS}=1mA$; $T_J=175^{\circ}C$	1200	>1400		V
Pulsed drain current	$I_{Dpulsed}$	$V_{GS}=20V$; $T_J=25^{\circ}C$ $V_{GS}=20V$; $T_J=100^{\circ}C$ limited by T_J , $tp=300\mu s$		180 150		A
Continuous drain current	I_D	$V_{GS}=20V$; $T_J=25^{\circ}C$ $V_{GS}=20V$; $T_J=100^{\circ}C$			80 70	A
Continuous drain power	P	$V_{GS}=20V$; $T_J=25^{\circ}C$		170		W
Maximum- junction temperature	T_{Jmax}	Recommended range During processing / soldering			195 250	$^{\circ}C$

Electrical and Thermal Characteristics						
*Characteristics	Symbol	Comments	Min	Typ	Max	Units
Gate threshold voltage	V_{TH}	$V_{DS}=1V$; $I_{DS}=20mA$; $T_J=25^{\circ}C$ $V_{DS}=1V$; $I_{DS}=20mA$; $T_J=175^{\circ}C$	2.92	3.06 2.05	3.20	V
Gate leakage	I_{GSS}	$V_{GS}=20V$; $V_{DS}=0$; $T_J=25^{\circ}C$ $V_{GS}=20V$; $V_{DS}=0$; $T_J=175^{\circ}C$		15 200		pA
Drain leakage	I_{DSS}	$V_{DS}=1000V$; $V_{GS}=0$; $T_J=25^{\circ}C$ $V_{DS}=1000V$; $V_{GS}=0$; $T_J=175^{\circ}C$		1 75		nA
Drain-source on-resistance	$R_{DS(on)}$	$V_{GS}=20V$; $I_{DS}=40A$; $T_J=175^{\circ}C$ $V_{GS}=20V$; $I_{DS}=50A$; $T_J=25^{\circ}C$ $V_{GS}=20V$; $I_{DS}=50A$; $T_J=175^{\circ}C$ $V_{DS}=10V$; $I_{DS}=40A$; $T_J=25^{\circ}C$	15	19 26 19	24	m Ω
Transconductance	G_m	$V_{DS}=10V$; $I_{DS}=30A$; $T_J=25^{\circ}C$ $V_{DS}=10V$; $I_{DS}=40A$; $T_J=175^{\circ}C$		14 20		S
Input capacitance	C_{ISS}	$V_{GS}=0V$; $V_{DS}=200 / 1000V$		3250 / 3200		pF
Output capacitance	C_{OSS}	$f=1MHz$; $T_J=25^{\circ}C$		333 / 178		pF
Reverse transfer capacitance	C_{RSS}			51.3 / 33.6		pF
Stored energy at output	E_{OSS}	Double integral of C_{OSS} (up to 1000V)		180		μJ
Turn on switching energy (with body diode)	E_{ON}	$V_{GS}=-3/18V$; $V_{DD}=800V$; $R_{G(ext)}=0\Omega$ $I_{DS}=40A$; $L=100\mu H$; $T_J=25^{\circ}C$		1500		μJ
Turn off switching energy (with body diode)	E_{OFF}	Clamped inductive switching waveform test circuit. Figure 26.		800		μJ
Rise time	t_r	$V_{GS}=-3/18V$; $V_{DD}=800V$; $R_{G(ext)}=0\Omega$ $I_{DS}=40A$; $L=80\mu H$; $T_J=25^{\circ}C$		55		ns
Fall time	t_f	Clamped inductive switching waveform test circuit. Figure 26.		45		ns
Turn off delay time	$t_{d(on)}$ $t_{d(off)}$	Relative to V_{DS} inductive load. Figure 26.		45 130		ns
Gate Charge	Q_G	$V_{GS}=-3/18V$; $V_{DD}=800V$; $R_{G(ext)}=1000\Omega$ $I_{DS}=16A$; $R_L=47\Omega$; $I_{GS}=25mA$; $T_J=25^{\circ}C$ Figure 27.		240		nC
Internal gate resistance	R_G	$f=1Mz$; $V_{AC}=25mV$; $T_J=25^{\circ}C$ Open drain		9		Ω
Thermal resistance:Junction to Case	R_{JC}			0.37		$^{\circ}C/W$

Body diode characteristics						
*Characteristics	Symbol	Comments	Min	Typ	Max	Units
Diode forward voltage	V_F	$I_F=10A; V_{GS}=0V; T_J=25^\circ C$ $I_F=10A; V_{GS}=0V; T_J=175^\circ C$ $I_F=20A; V_{GS}=-4V; T_J=25^\circ C$ $I_F=20A; V_{GS}=-4V; T_J=175^\circ C$		2.66 2.27 3.66 3.18		V
Pulsed diode current	$I_{S(pulsed)}$	$V_{GS}=0V; V_{DS}=-3V; T_J=25^\circ C$ $V_{GS}=0V; V_{DS}=-3V; T_J=175^\circ C$		17.8 32.1		A
Reverse recovery time	t_{rr}	$V_{DD}=800V; V_{GS}=-3V; I_{DS}=60A$ $R_{G(ext)}=0\Omega L=100\mu H di/dt=1200A/\mu s$ Clamped inductive switching waveform test circuit. Figure 26.		50		ns
Reverse recovery charge	Q_{rr}			990		nC
Peak reverse recovery current	I_{RRM}			30		A

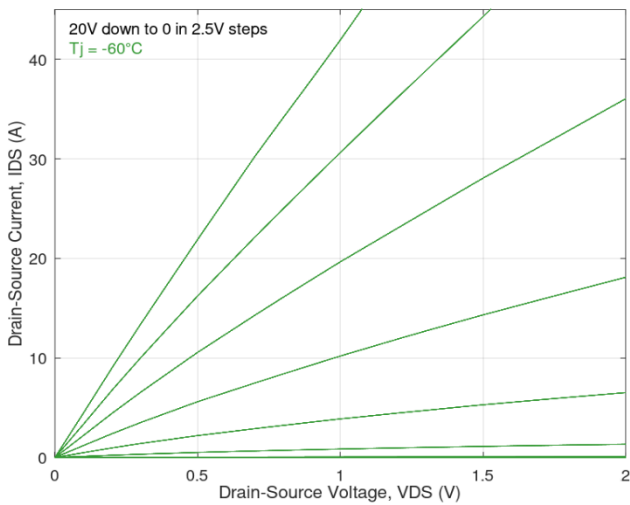

Figure 1: Low temperature output characteristics†.

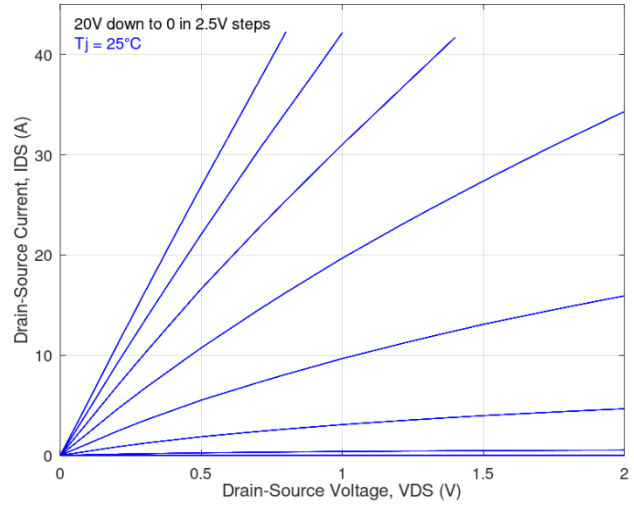

Figure 2: Room temperature output characteristics†.

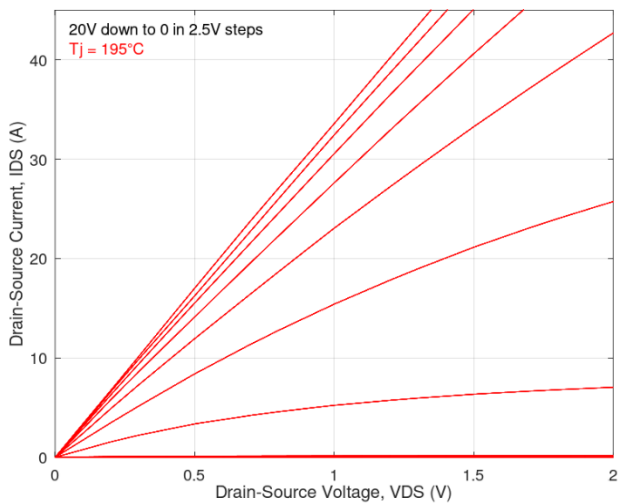

Figure 3: High temperature output characteristics†.

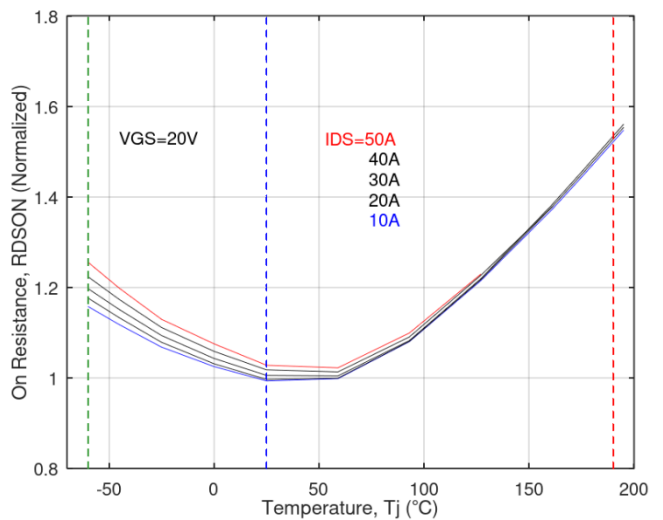

Figure 4: Normalized on-resistance vs. temperature. Dashed vertical lines indicate to room (25°C), high (195°C) and low (-65°C) temperatures.

† $t_p=300\mu s$ in pulsed IV measurements.

Unless stated otherwise, temperature corresponds to junction temperature.

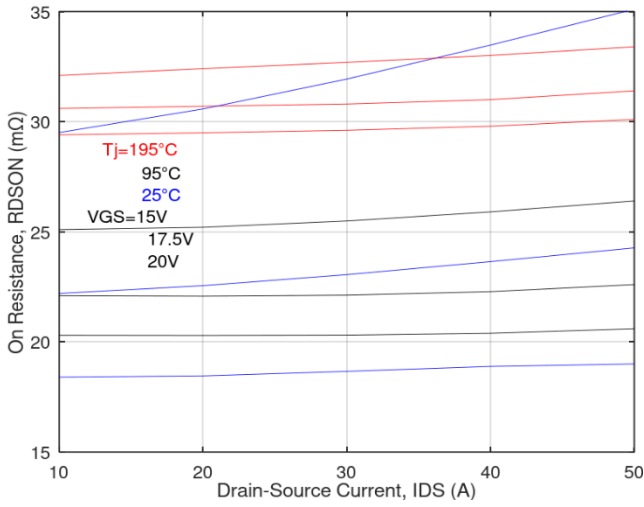

Figure 5: On-resistance vs. drain current.

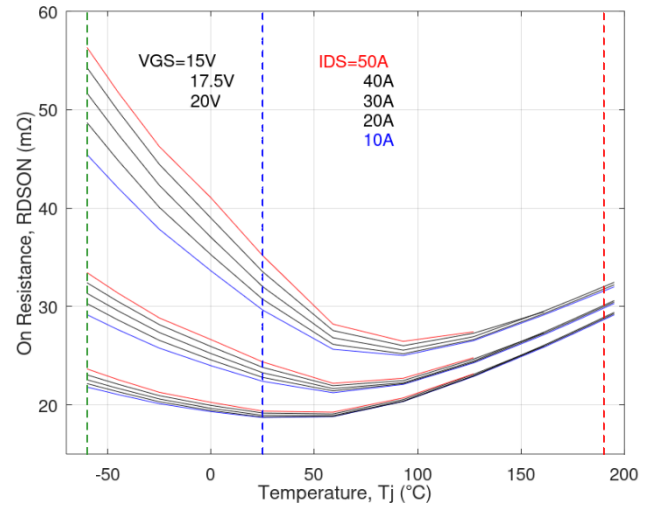

Figure 6: On-resistance vs. temperature. Dashed vertical lines indicate to room (25°C), high (195°C) and low (-60°C) temperatures.

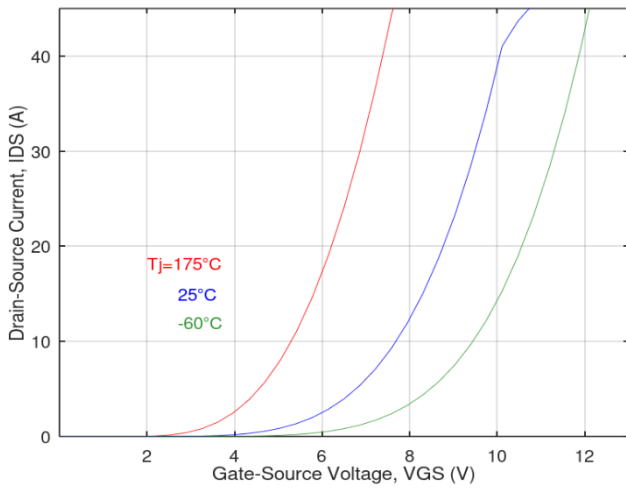

Figure 7: Transfer characteristics†.

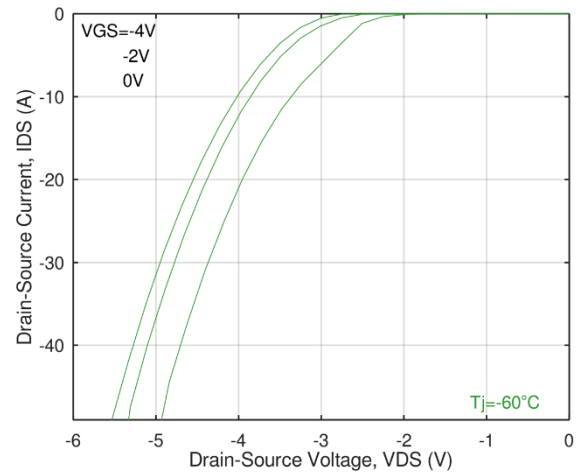

Figure 8: Low temperature body diode characteristics†.

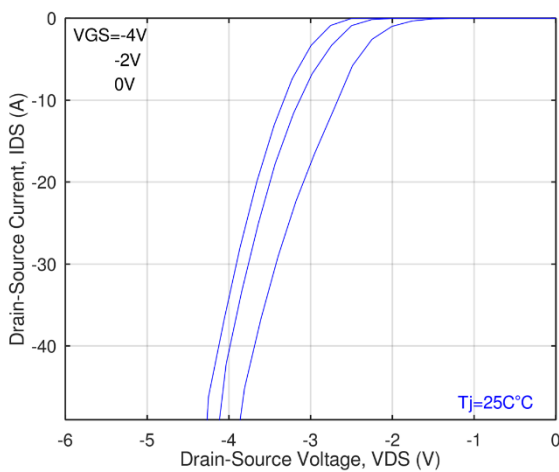

Figure 9: Room temperature body diode characteristics†.

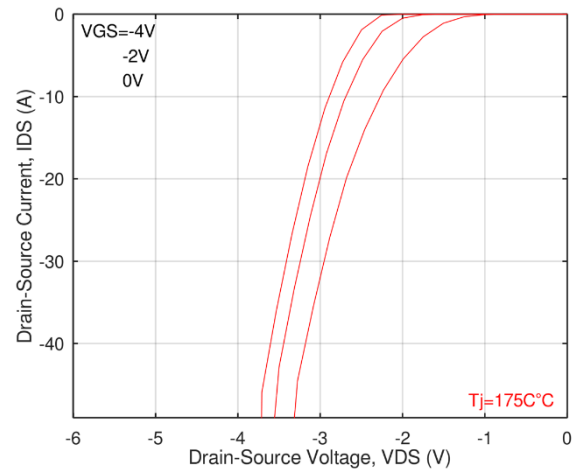

Figure 10: High temperature body diode characteristics†.

† $t_p=300\mu s$ in pulsed IV measurements.
Unless stated otherwise, temperature corresponds to junction temperature.

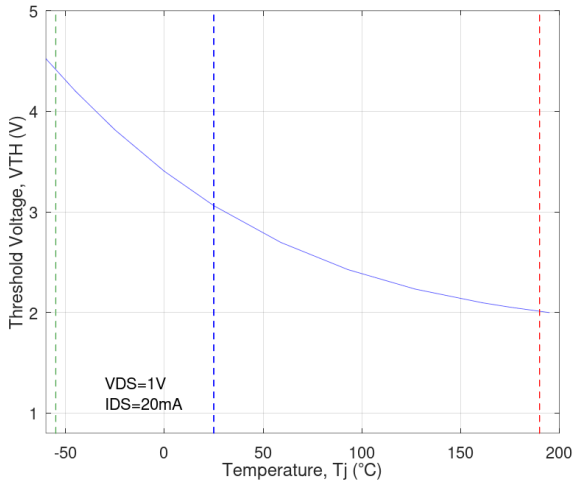

Figure 11: Threshold vs. temperature.

Dashed vertical lines indicate to room (25°C), high (190°C) and low (-65°C) temperatures.

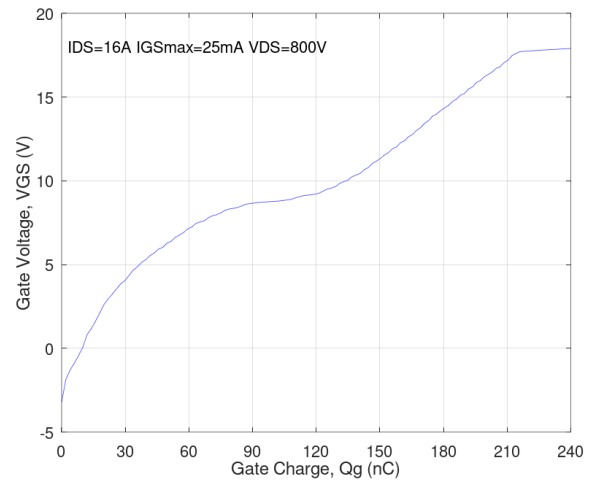

Figure 12: Gate charge characteristics.

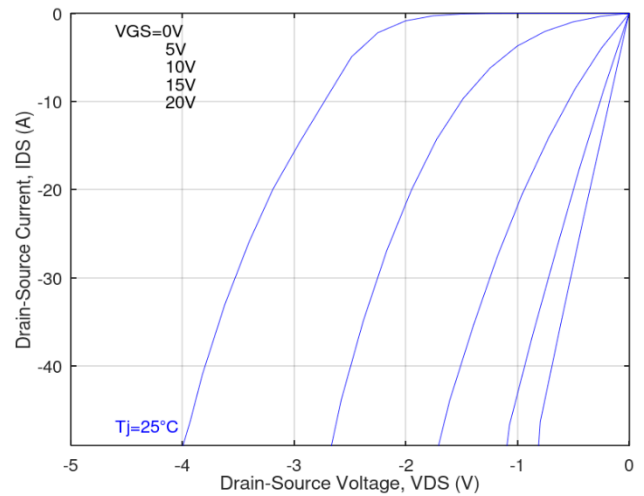
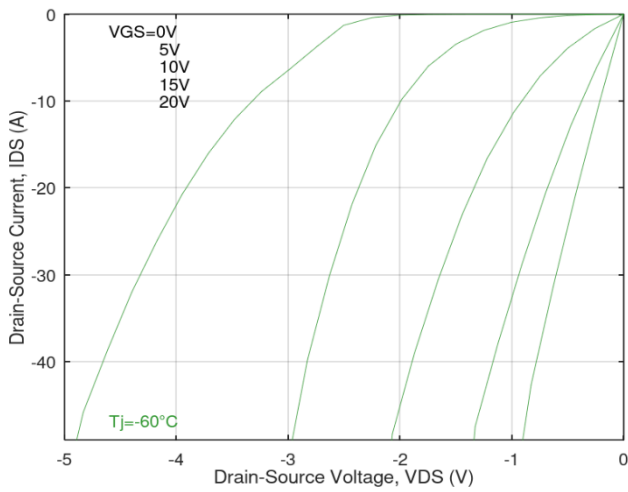

Figure 13: Low temperature third quadrant characteristics†. **Figure 14:** Room temperature third quadrant characteristics†.

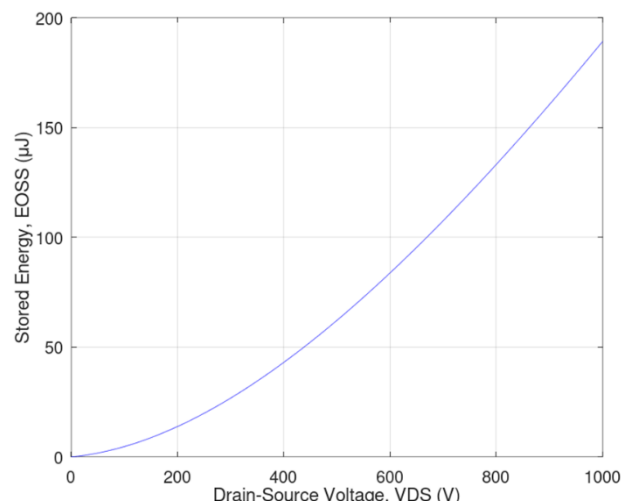
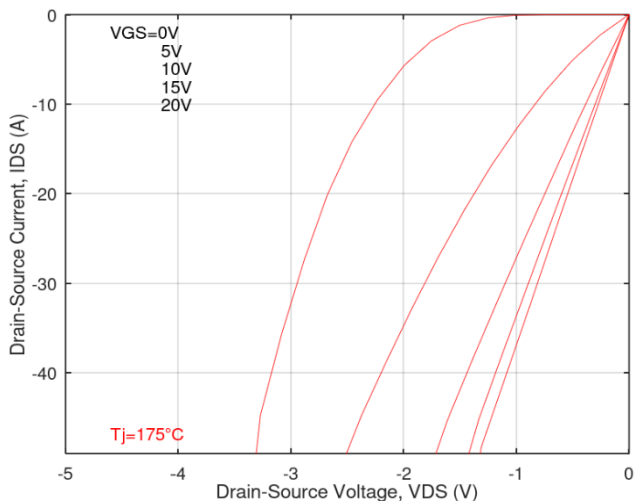

Figure 15: High temperature third quadrant characteristics†.

Figure 16: Output capacitor stored energy.

† $t_p=300\mu s$ in pulsed IV measurements.

Unless stated otherwise, temperature corresponds to junction temperature.

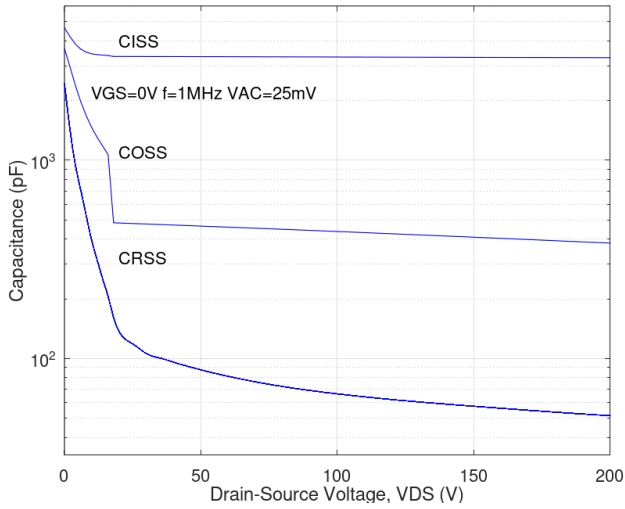

Figure 17: Capacitance vs. drain voltage.

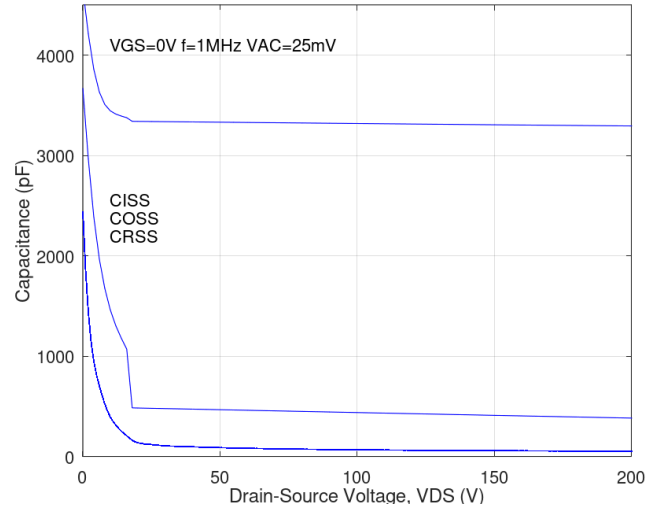

Figure 18: Capacitance vs. drain voltage.

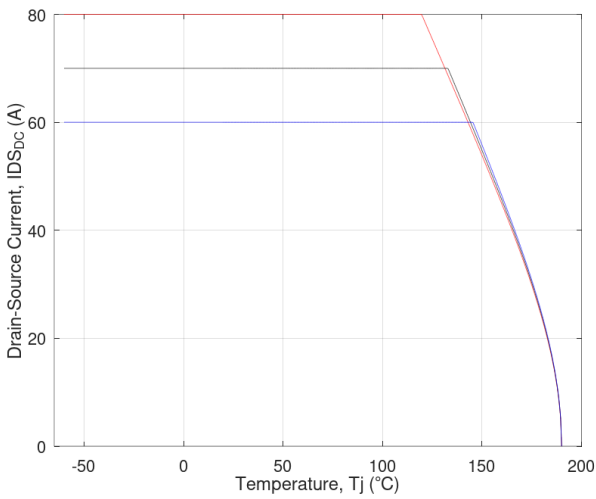

Figure 19: Continuous drain current vs. temperature.

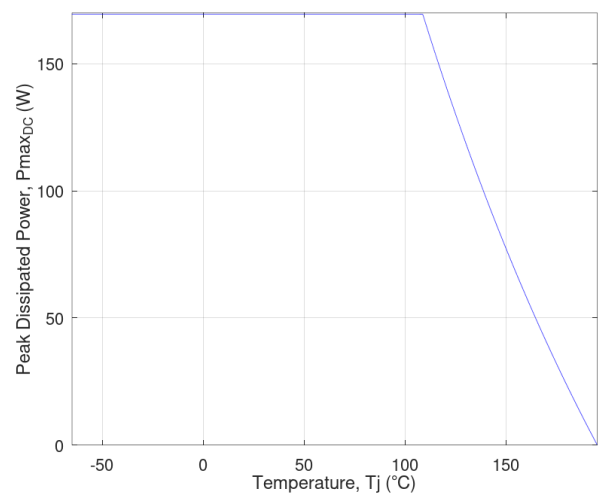

Figure 20: Power dissipation derating vs. temperature. (IDS=80A)

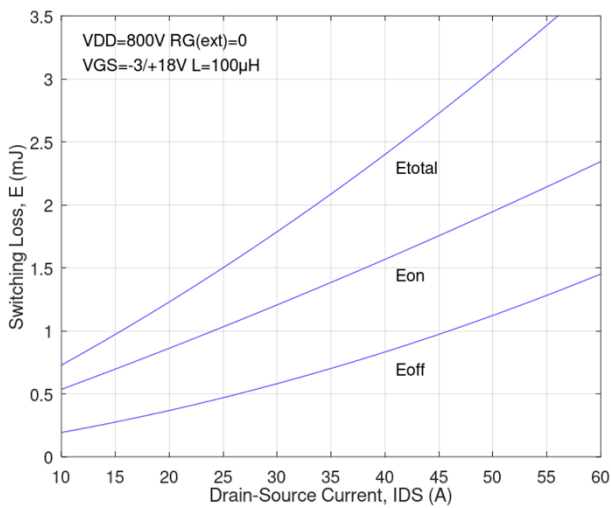

Figure 21: Clamped inductive switching energy vs. drain current at 800V VDD.

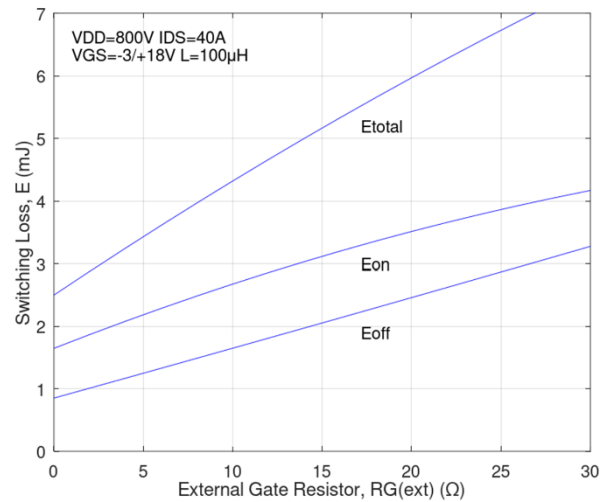

Figure 22: Clamped inductive switching energy vs. external gate resistance.

Unless stated otherwise, temperature corresponds to junction temperature.

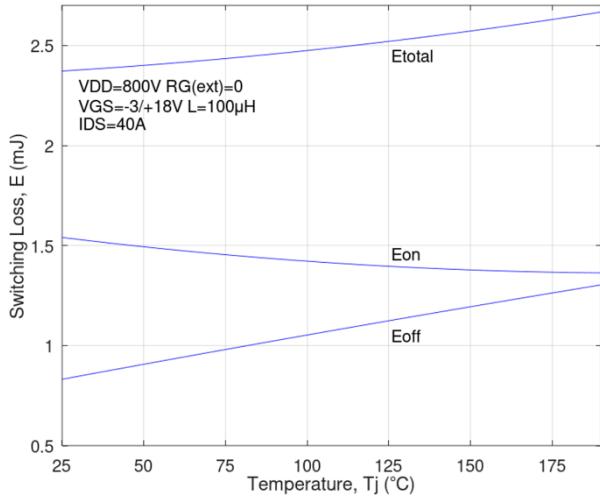

Figure 23: Clamped inductive switching energy vs. temperature.

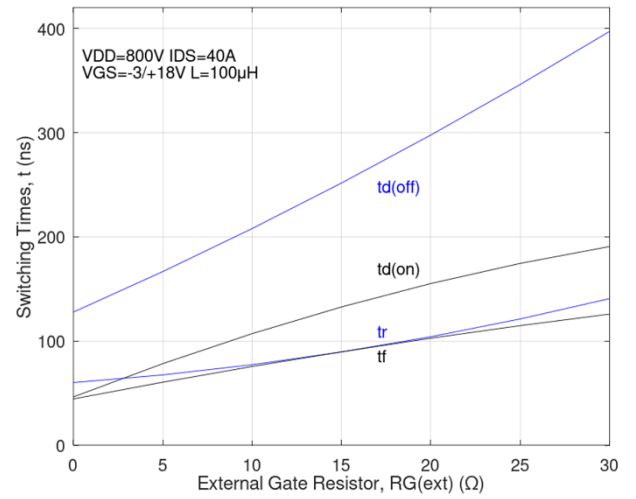

Figure 24: Switching times vs. external gate resistance.

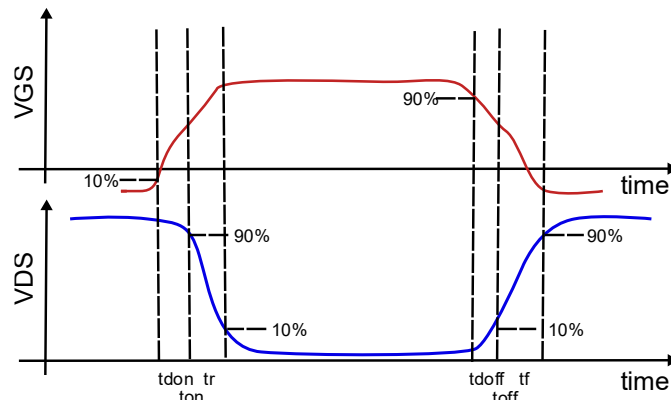

Figure 25: Timing references.

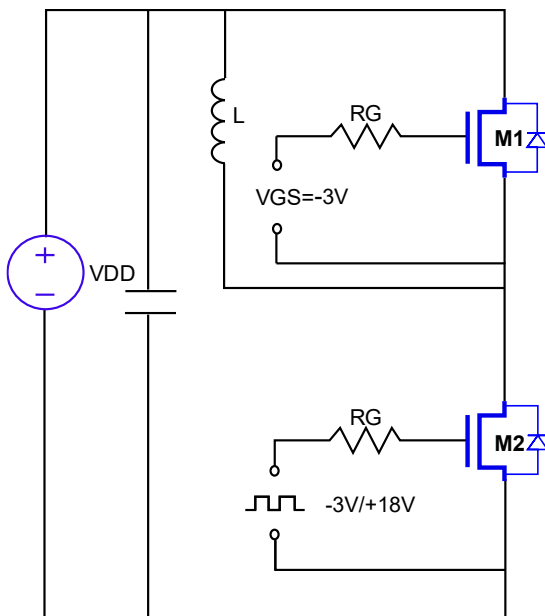

Figure 26: Clamped inductive switching waveform test circuit.

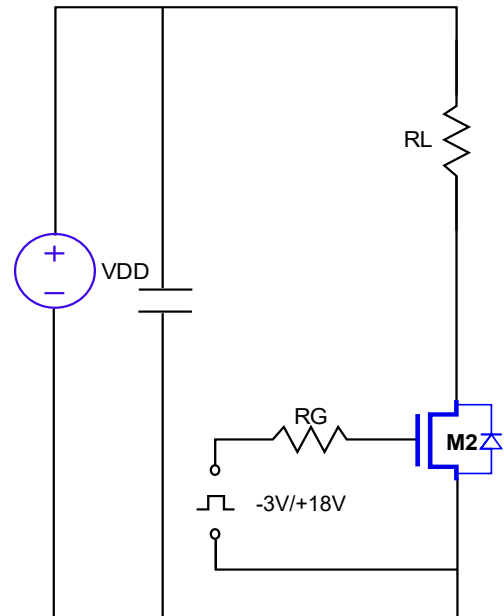
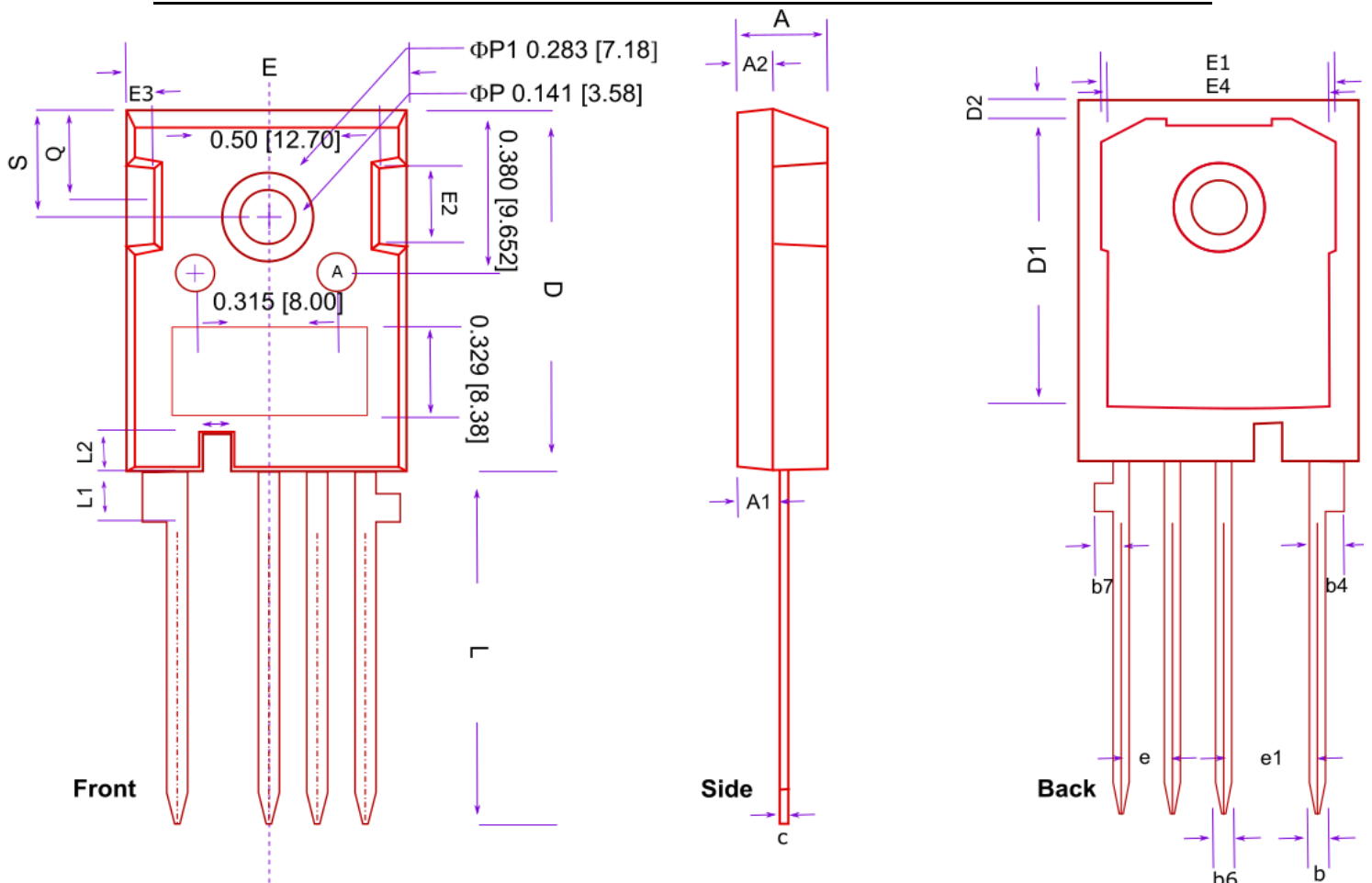
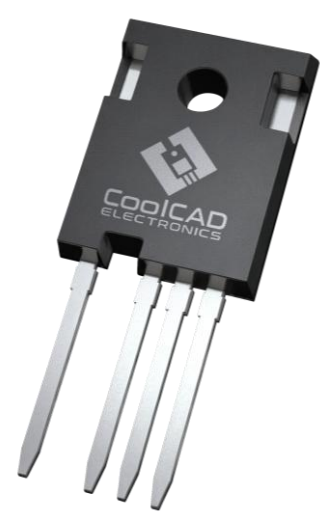

Figure 27: Gate charge test circuit.

Unless stated otherwise, temperature corresponds to junction temperature.



	min (mm)	nom (mm)	max (mm)	min (inch)	nom (inch)	max (inch)
D	23.30	23.45	23.60	9.17×10 ⁻¹	9.23×10 ⁻¹	9.29×10 ⁻¹
D1	15.85	16.55	17.25	6.24×10 ⁻¹	6.52×10 ⁻¹	6.79×10 ⁻¹
D2	1.02	1.17	1.32	0.40×10 ⁻¹	0.46×10 ⁻¹	0.52×10 ⁻¹
E	15.75	15.94	16.13	6.20×10 ⁻¹	6.28×10 ⁻¹	6.35×10 ⁻¹
E1	13.89	14.02	14.15	5.47×10 ⁻¹	5.52×10 ⁻¹	5.57×10 ⁻¹
E2	3.68	4.39	5.10	1.45×10 ⁻¹	1.73×10 ⁻¹	2.01×10 ⁻¹
E3	1.00	1.45	1.90	0.39×10 ⁻¹	0.57×10 ⁻¹	0.75×10 ⁻¹
E4	12.38	12.91	13.43	4.87×10 ⁻¹	5.08×10 ⁻¹	5.29×10 ⁻¹
L	17.31	17.57	17.82	6.81×10 ⁻¹	6.92×10 ⁻¹	7.02×10 ⁻¹
L1	3.97	4.17	4.37	1.56×10 ⁻¹	1.64×10 ⁻¹	1.72×10 ⁻¹
L2	2.35	2.50	2.65	0.93×10 ⁻¹	0.98×10 ⁻¹	1.04×10 ⁻¹
S	6.04	6.15	6.30	2.38×10 ⁻¹	2.42×10 ⁻¹	2.48×10 ⁻¹
Q	5.49	5.75	6.00	2.16×10 ⁻¹	2.26×10 ⁻¹	2.36×10 ⁻¹
A	4.83	5.02	5.21	1.90×10 ⁻¹	1.98×10 ⁻¹	2.05×10 ⁻¹
A1	2.29	2.415	2.54	0.90×10 ⁻¹	0.95×10 ⁻¹	1.00×10 ⁻¹
A2	1.86	1.99	2.12	0.73×10 ⁻¹	0.78×10 ⁻¹	0.83×10 ⁻¹
e		2.54			1.00×10 ⁻¹	
e1		5.08			2.00×10 ⁻¹	
b	1.07		1.33	0.42×10 ⁻¹		0.52×10 ⁻¹
b4	2.39		2.94	0.94×10 ⁻¹		1.16×10 ⁻¹
b6	1.07		1.60	0.42×10 ⁻¹		0.63×10 ⁻¹
b7	1.30		1.70	0.51×10 ⁻¹		0.67×10 ⁻¹
c	0.55		0.68	0.22×10 ⁻¹		0.27×10 ⁻¹
ΦP	3.51	3.58	3.65	1.38×10 ⁻¹	1.41×10 ⁻¹	1.44×10 ⁻¹
ΦP1		7.18			2.83×10 ⁻¹	



CAUTION: These devices are ESD sensitive. Use proper handling procedures.

Disclaimer: These specifications may not be considered as a guarantee of components characteristics. Components have to be tested depending on intended application as adjustments may be necessary. The use of CoolCAD Electronics components in life support appliances and systems are subject to written approval of CoolCAD Electronics.